

WK20-ZMQ front nut mount socket assembling instructio-Solder

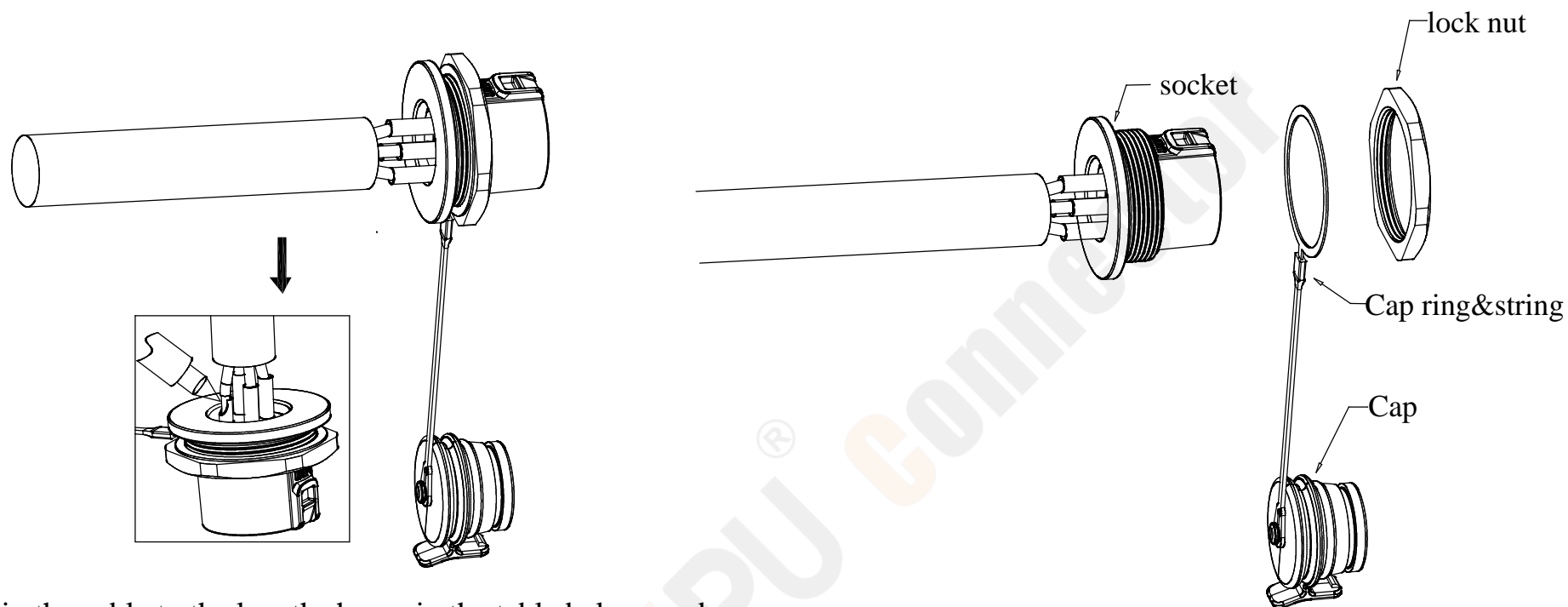

1、 Strip the cable to the length shown in the table below, and solder the wire to the pin .

Note that the soldering iron should not burn the pin during the process. After soldering, put a heat shrink tube on the solder pin and wrappen the heat shrink tube.

· Strip length

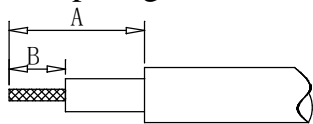

Series	A (mm)	B (mm)
WK20	25	8

2、 Disassemble the connector parts

WK20-ZMQ front nut mount socket assembling instructio-Solder

Panel Cutout (mm)

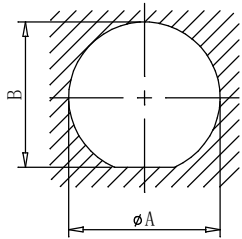

Series	A	B
WK20	28	26.3

3、 Drill hole on the panel according to the cutout size in the table.

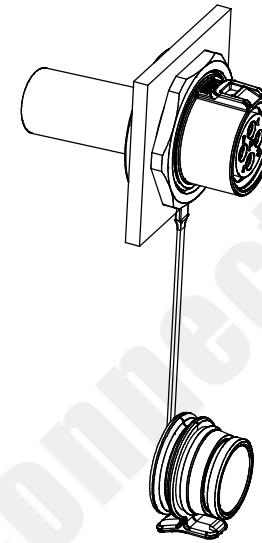

4、 Install the socket into the panel and tighten it with the lock nut by torque of 1.5-3N.m.

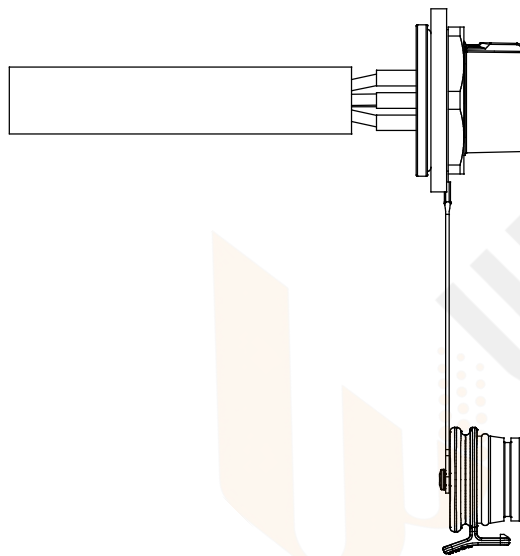

5、 Cover the cap to complete assembling.