

WK20-TEP Shield cable plug assembling instruction-Solder

1.Finished product

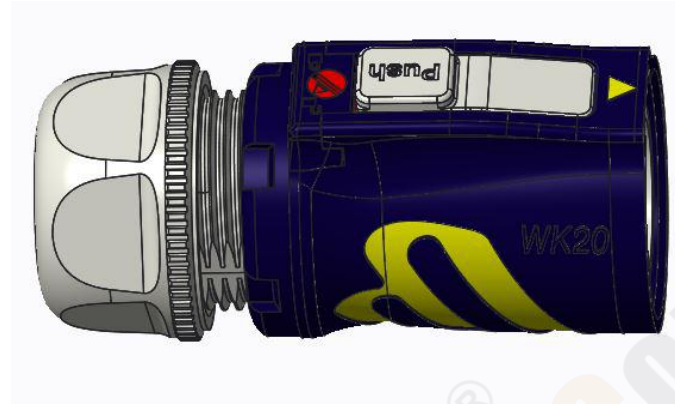

2.Disassemble the connector.

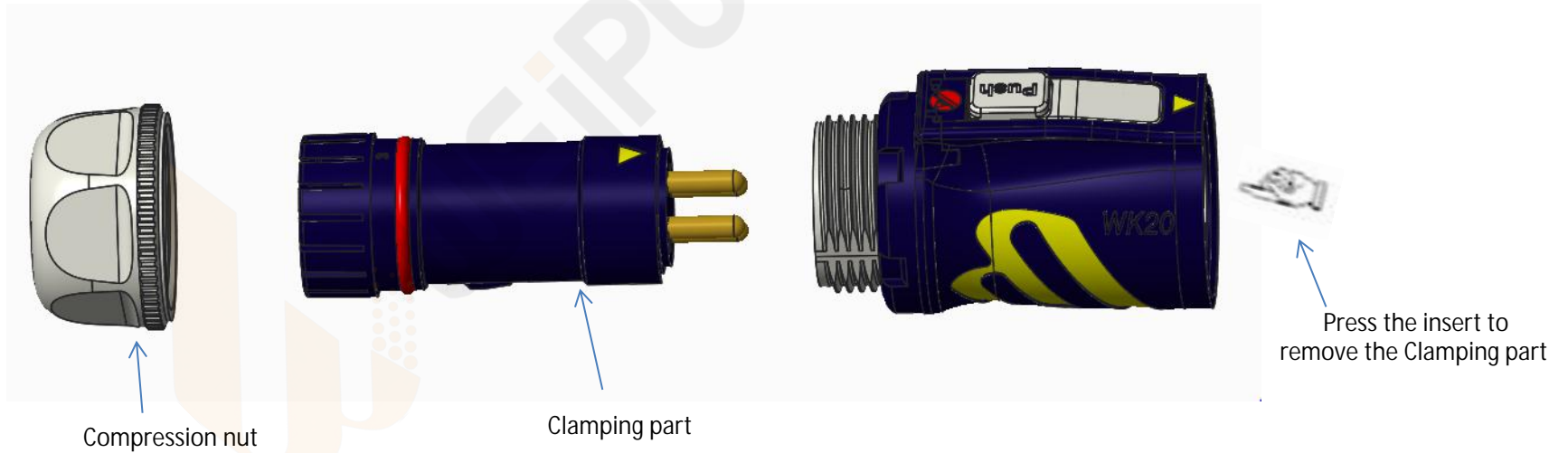

3、 Strip length

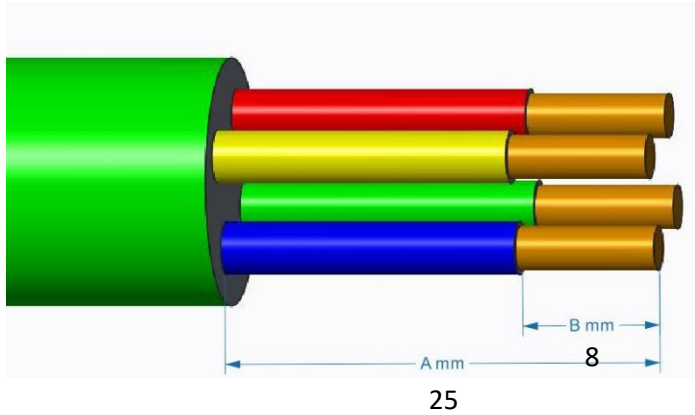

4、 Put the cable through compression nut and clamping part.

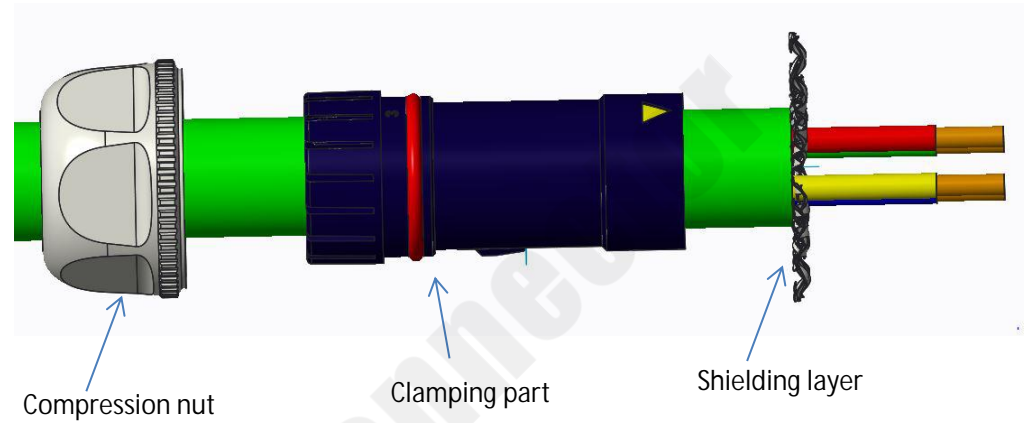

5、 Put the HS tube on wire

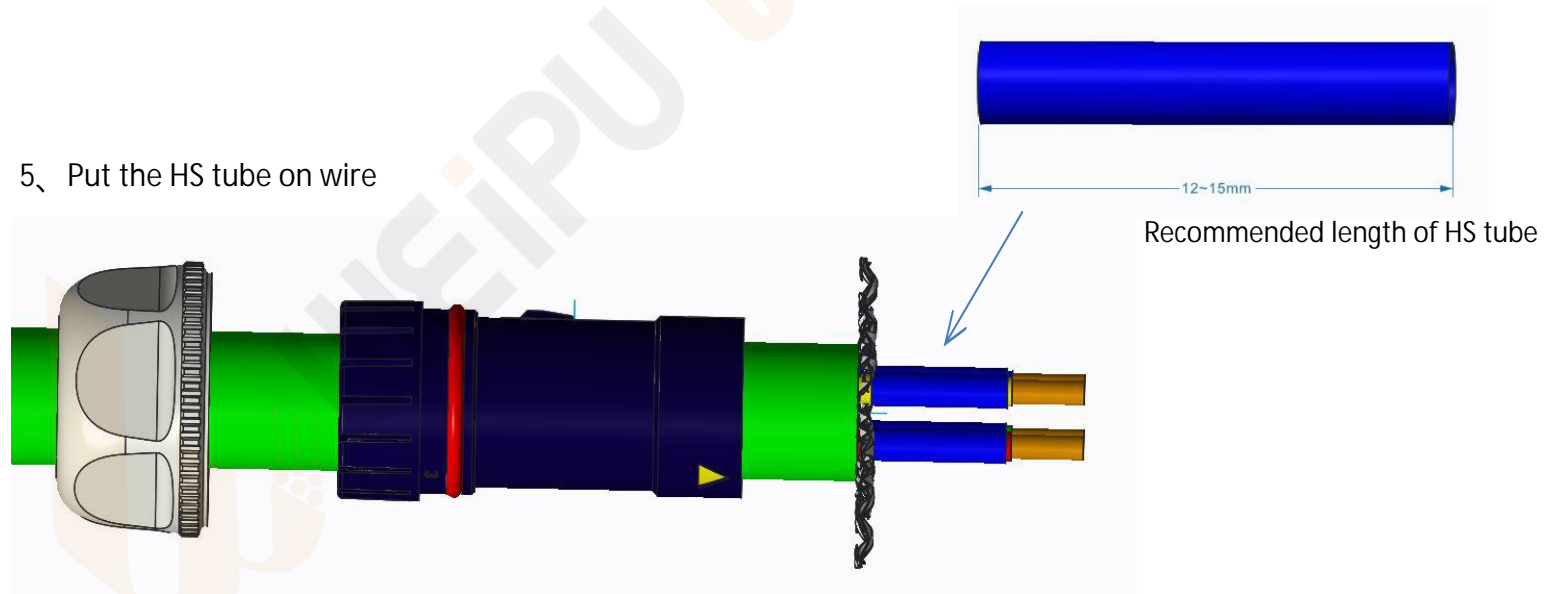

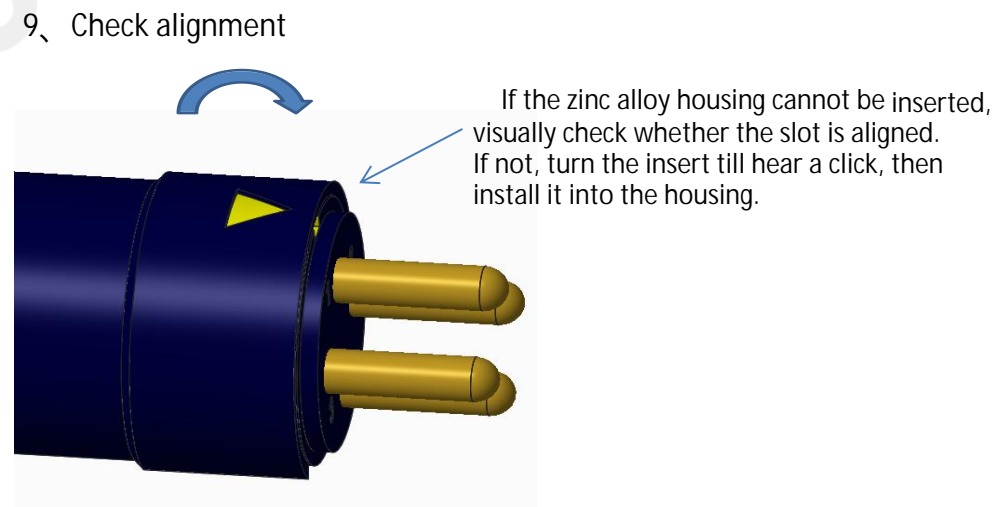
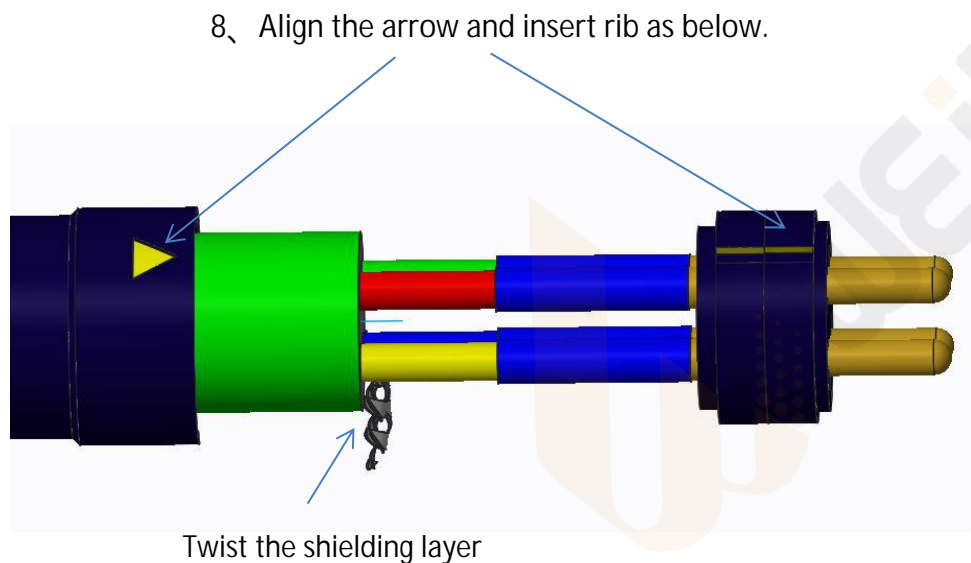
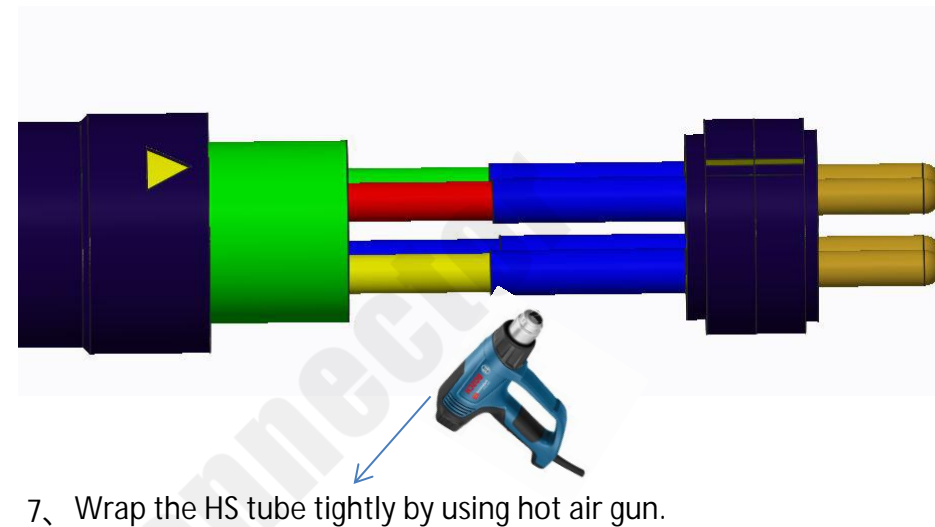
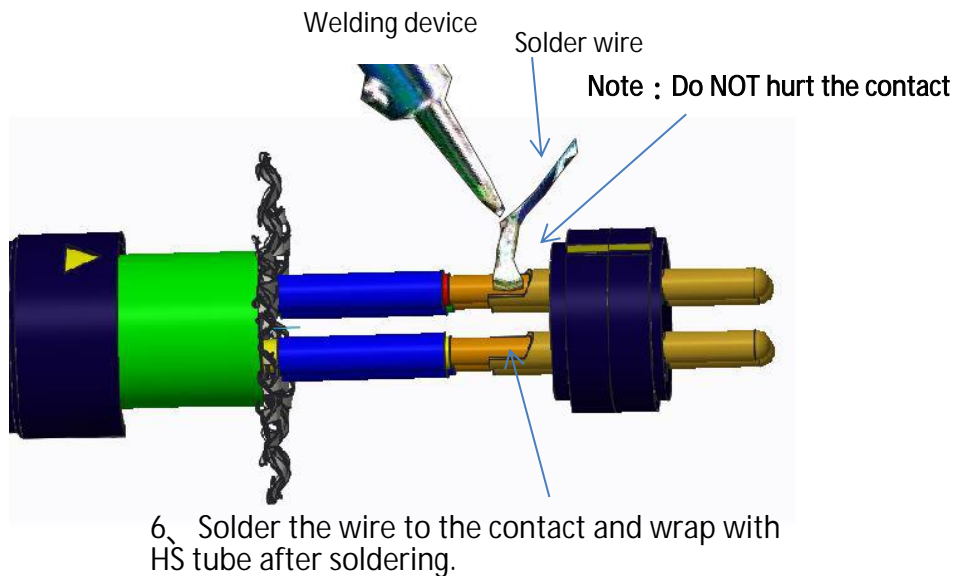

10、 Align the arrows at both ends according to the diagram and assemble them together

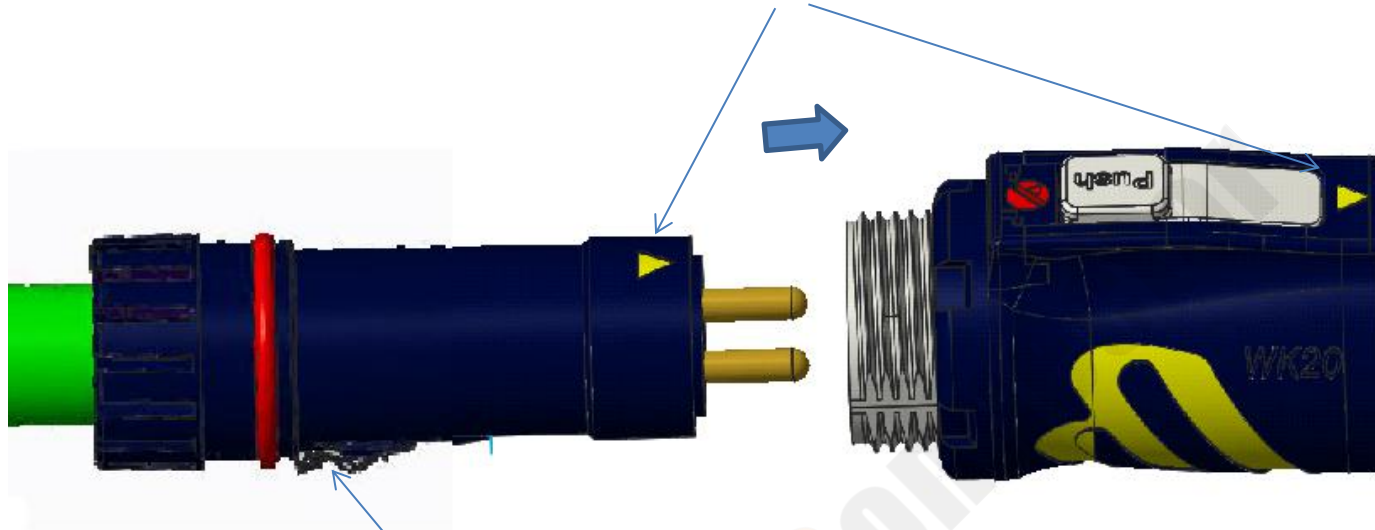

Note: Put the twisted shielding layer through the hole and flatten it for easy insertion.

11、 Use a torque wrench to tighten the Compression nut, with torque 3 N.m

