

# WK16-TEP Shield cable plug assembling instruction-Solder

## 1.Finished product

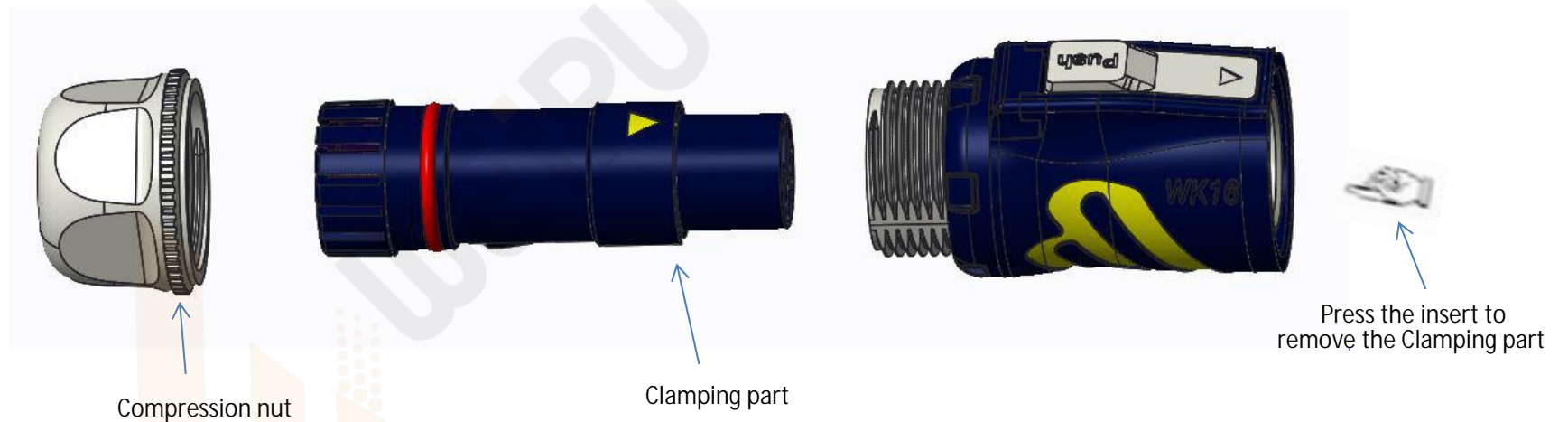

## 2.Disassemble the connector.



3、 Strip length

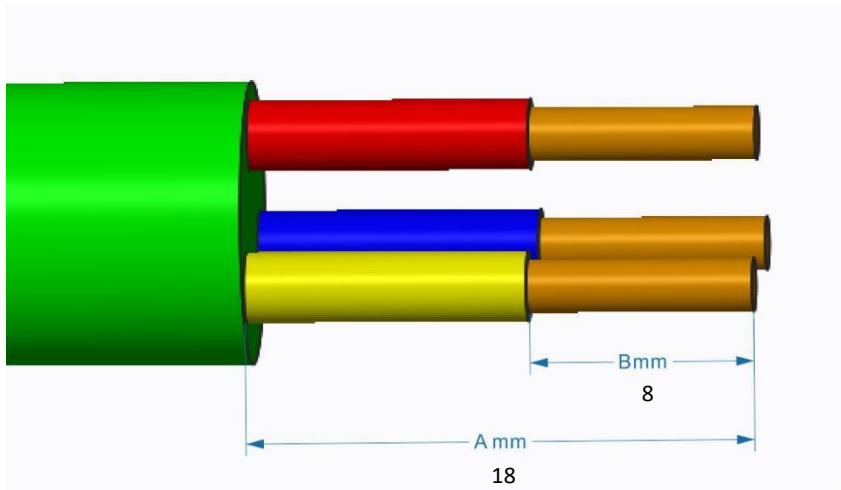

4、 Put the cable through compression nut and clamping part.

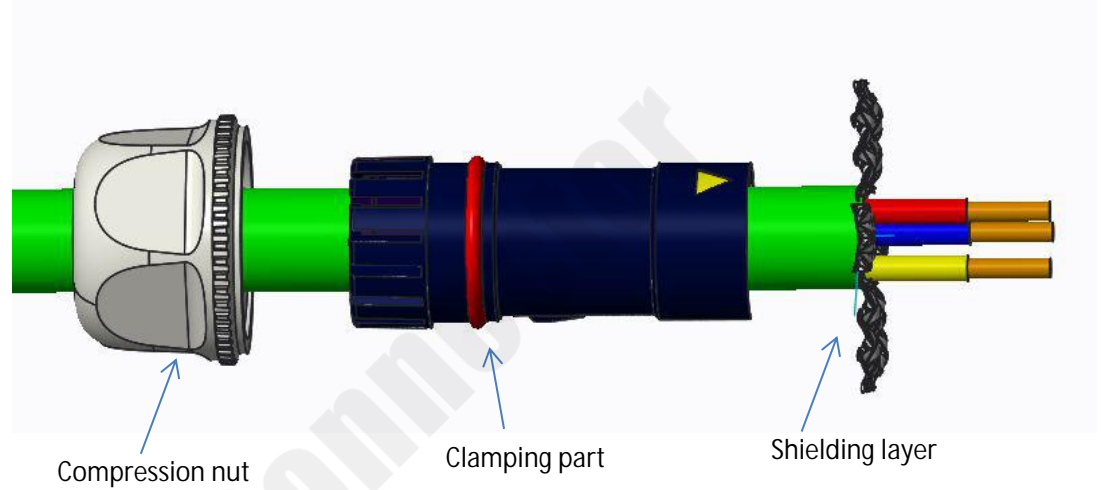

5、 Put the HS tube on wire

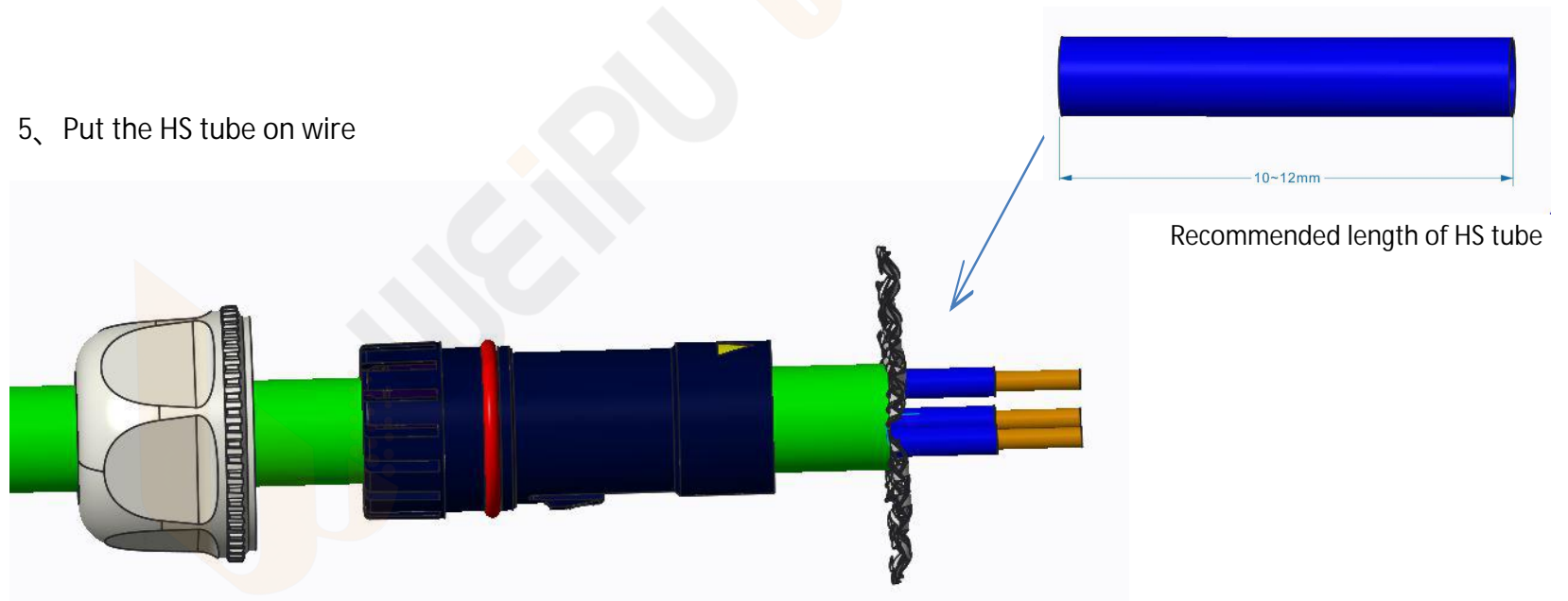

Welding device

Solder wire

Note : Do NOT hurt the contact

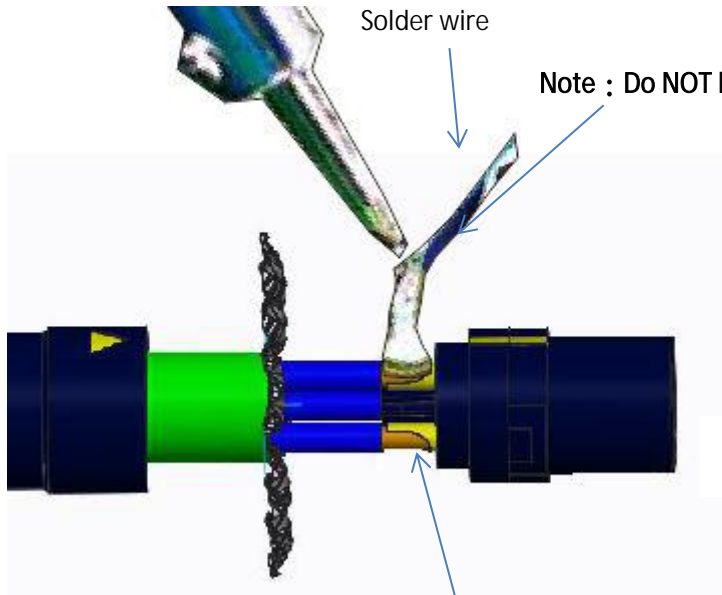

6、 Solder the wire to the contact and wrap with HS tube after soldering.

8、 Align the arrow and insert rib as below.

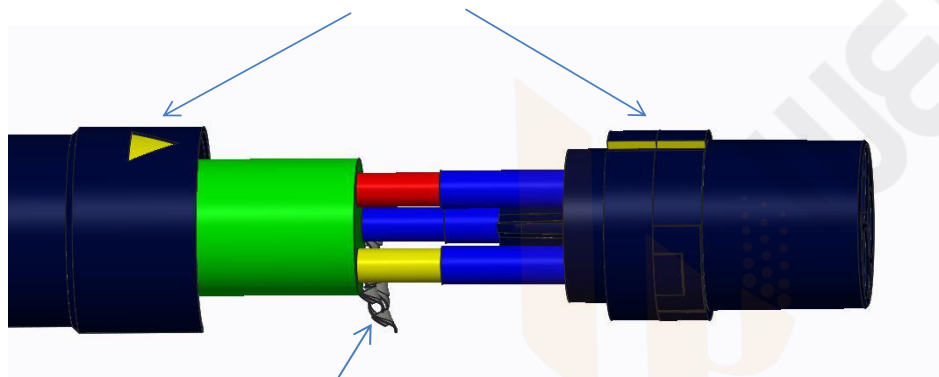

Twist the shielding layer

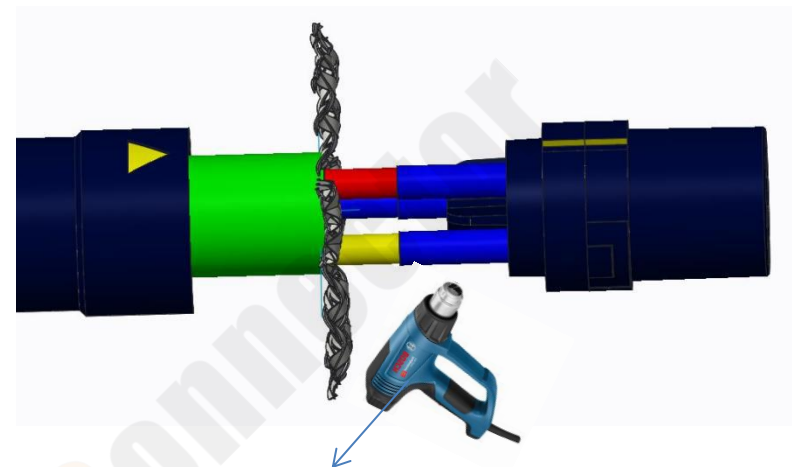

7、 Wrap the HS tube tightly by using hot air gun.

9、 Check alignment

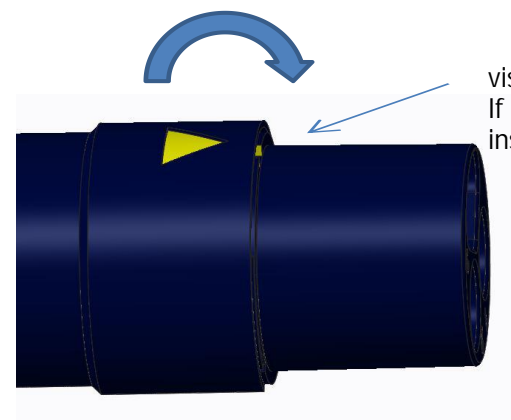

If the zinc alloy housing cannot be inserted, visually check whether the slot is aligned. If not, turn the insert till hear a click, then install it into the housing.

10、 Align the arrows at both ends according to the diagram and assemble them together

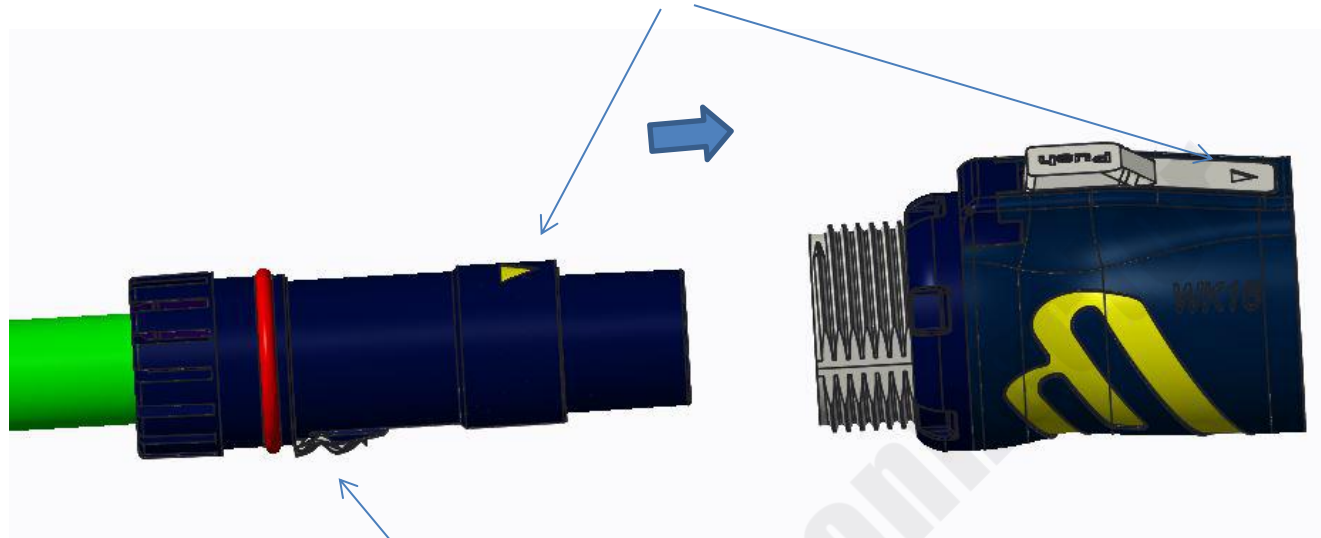

Note: Put the twisted shielding layer through the hole and flatten it for easy insertion.

11、 Use a torque wrench to tighten the Compression nut, with torque 2.5 N.m

